



#### RANGE OF PERFORMANCE

Flow rate up to 350 l/min (21 m<sup>3</sup>/h)

Head up to 20 m

#### LIMITS OF USE

Manometric suction lift up to 7 m

Liquid temperature up to + 90°C

Liquid temperature up to + 40°C in the NCOX version (with technopolymer impeller)

Environment temperature up to + 40°C

Passage of solid bodies Ø 10 mm

#### INSTALLATION AND USE

They are recommended for pumping water and liquids that are chemically non aggressive to the materials from which the pump is made. **THE OPEN IMPELLER DESIGN ALLOWS THE PUMPING OF LIQUIDS WITH RELATIVELY HIGH LEVELS OF IMPURITIES WITHOUT RISK OF CLOGGING THE IMPELLER. FOR THIS REASON THE NCO SERIES ARE SUITABLE FOR USE IN INDUSTRY, FOR THE TRANSFER OF WATER FROM CANALS, RIVERS, RESERVOIRS, TANKS, ETC.** The pumps must be installed in enclosed places, or at least protected against inclement weather.

**GUARANTEE 2 YEARS** subject to our general terms of sale.

#### CONSTRUCTION CHARACTERISTICS

- **PUMP BODY:** cast iron, with threaded ports ISO 228/1.

- **BODY BACK-PLATE:** stainless steel AISI 304.

- **OPEN IMPELLER:** stainless steel AISI 316.

- **MOTOR SHAFT:** stainless steel EN 10088-3 - 1.4104.

- **MECHANICAL SEAL:** ceramic - graphite - NBR.

- **ELECTRIC MOTOR:** the pumps are close-coupled to a carefully matched electric motor, quiet running, totally enclosed fan cooled, suitable for continuous duty.

**NCO M:** single-phase 230V-50 Hz with capacitor and thermal overload protector.

**NCO:** three-phase 230/400 V - 50 Hz.

- **INSULATION:** class F.

- **PROTECTION:** IP 44.

#### OPTIONS ON REQUEST

⇒ impeller in **technopolymer** (NCO M...X - NCO...X)

⇒ special mechanical seal

⇒ other voltages or frequency 60 Hz

#### CONSTRUCTION AND SAFETY STANDARDS

EN 60034-1

IEC 34-1

CEI 2-3



## DIMENSIONS

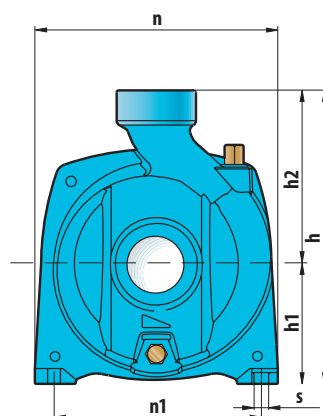
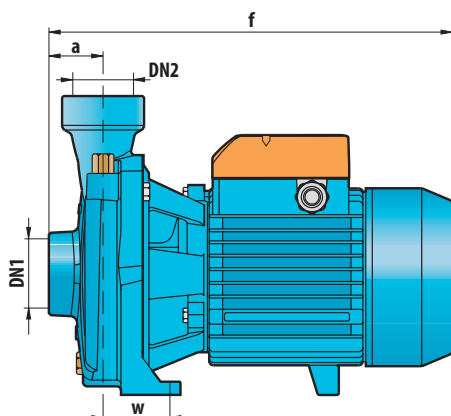



## NCO

centrifugal pumps with open impeller

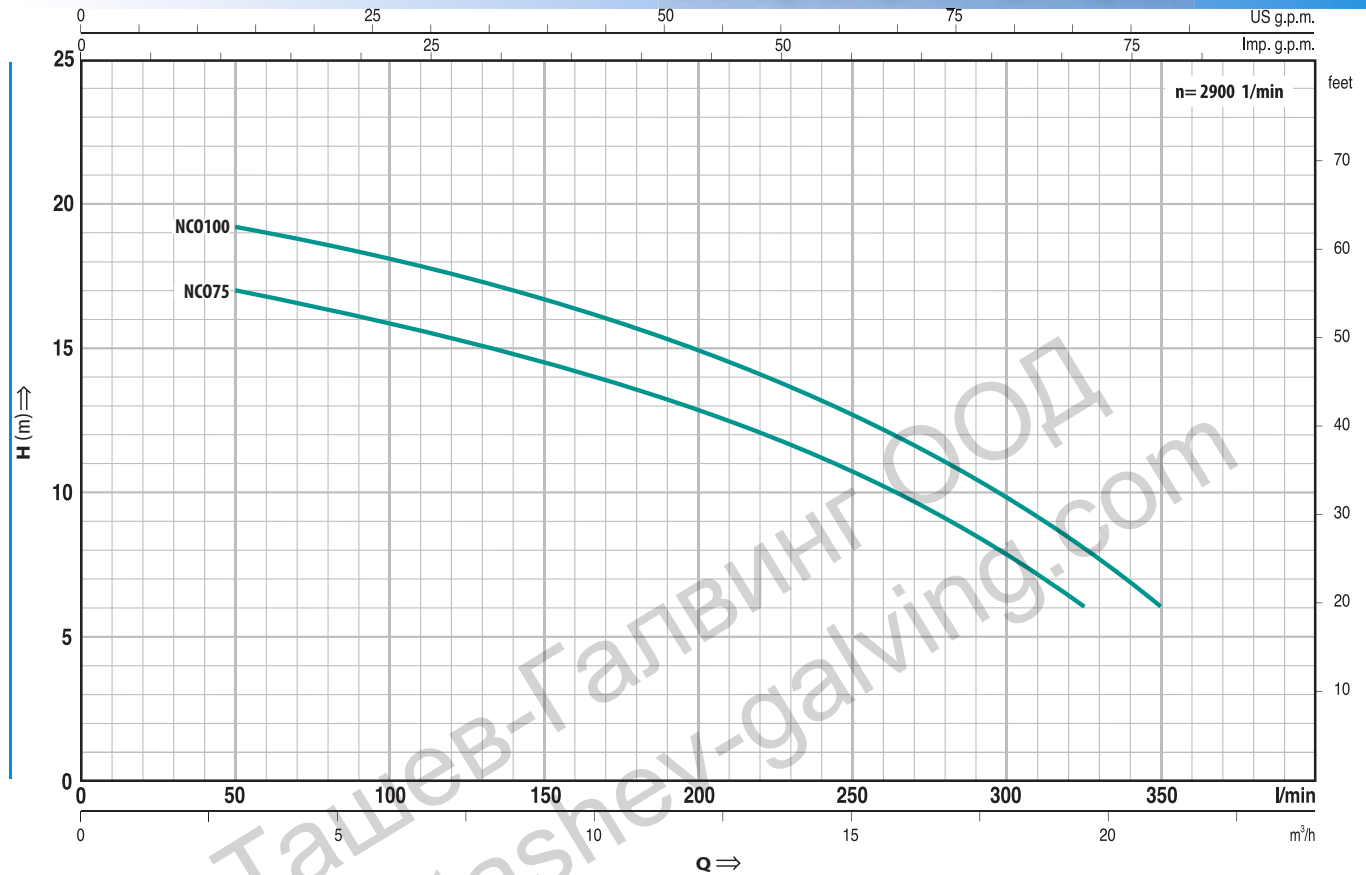

Q = Flow rate H = Total manometric head

Tolerance of the performance curves according to EN ISO 9906 App. A.

TYPE		POWER		m³/h l/min	0	3	6	9	12	15	18	19.5	21
Single-phase	Three-phase	kW	HP		0	50	100	150	200	250	300	325	350
NCO 75M	NCO 75	0.55	0.75	H metres	18	17	16	14.5	13	10.5	8	6	
NCO 100M	NCO 100	0.75	1		20	19.5	18	16.5	15	12.5	10	8	6

## DIMENSIONS AND WEIGHTS

TYPE		PORTS		DIMENSIONS mm									kg	
Single-phase	Three-phase	DN1	DN2	a	f	h	h1	h2	n	n1	w	s	1~	3~
NCO 75M	NCO 75	1 1/2"	1 1/2"	41	297	227	92	135	190	160	50	10	12.7	11.8
NCO 100M	NCO 100												12.8	11.9